



**Magnetic Drive Pump
Resistant to Abnormal Operations**

Even Better Dry-Running Resistance and Efficiency Than Previous Models. IWAKI MX Magnetic Drive Pumps - Reliable & Energy Efficient.



Self-Radiating Structure

Through heat-dispersion holes provided in the fixed portions of the impeller and the magnet capsule, the liquid around the spindle and the bearing is forced to circulate so that heat generated by sliding can be reduced effectively.

Thus, thermal deformation and melt are prevented.

(Except MX-70, 100)



Robust Structure

All stress bearing portions, such as the front and rear casings, are reinforced by means of ribs to improve the pressure resistance and the mechanical strength of the pump.

The bearing is not only fixed by conventional press fit but is also sandwiched between the abutting portion in the depth of the magnet capsule and the rear end of the impeller to improve its reliability under high temperature.

(Except MX-70, 100)

MX-402(H), 403(H) and 505 models: an unplugging preventive lock pin is adopted for ensuring more steady securing.

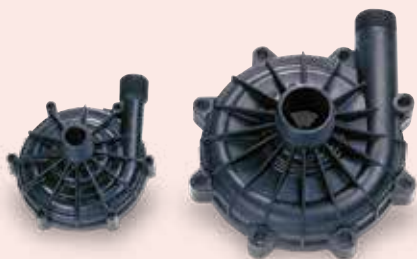

Enhanced Suction Characteristics and Pump Efficiency (MX-505)

Lineup of MX-505 with dramatically improved suction characteristics and pump efficiency, while maintaining the original durable structure.



Volute Casing Divided Into Two Sections

The series is the first resin magnet pump which uses the pump casing divided into the front casing and the rear casing to form a vortex chamber as an ideal form. Therefore, the internal leak phenomenon, which means that the liquid getting out of the impeller returns to the pump casing, is suppressed to a minimum and the liquid is efficiently guided to the discharge port to enhance overall efficiency.

(Except MX-70/400/505)



Non-Contact Structure

By installing the driving magnet and the driven magnet in an inventive way, the movement of the magnet capsule is controlled by magnetic force to prevent the rear thrust and the rear portion of the bearing coming into contact with each other continuously even during dry running. This structure reduces heat generation and secures lubricant routes. (Except MX-70, 100)



MX-505

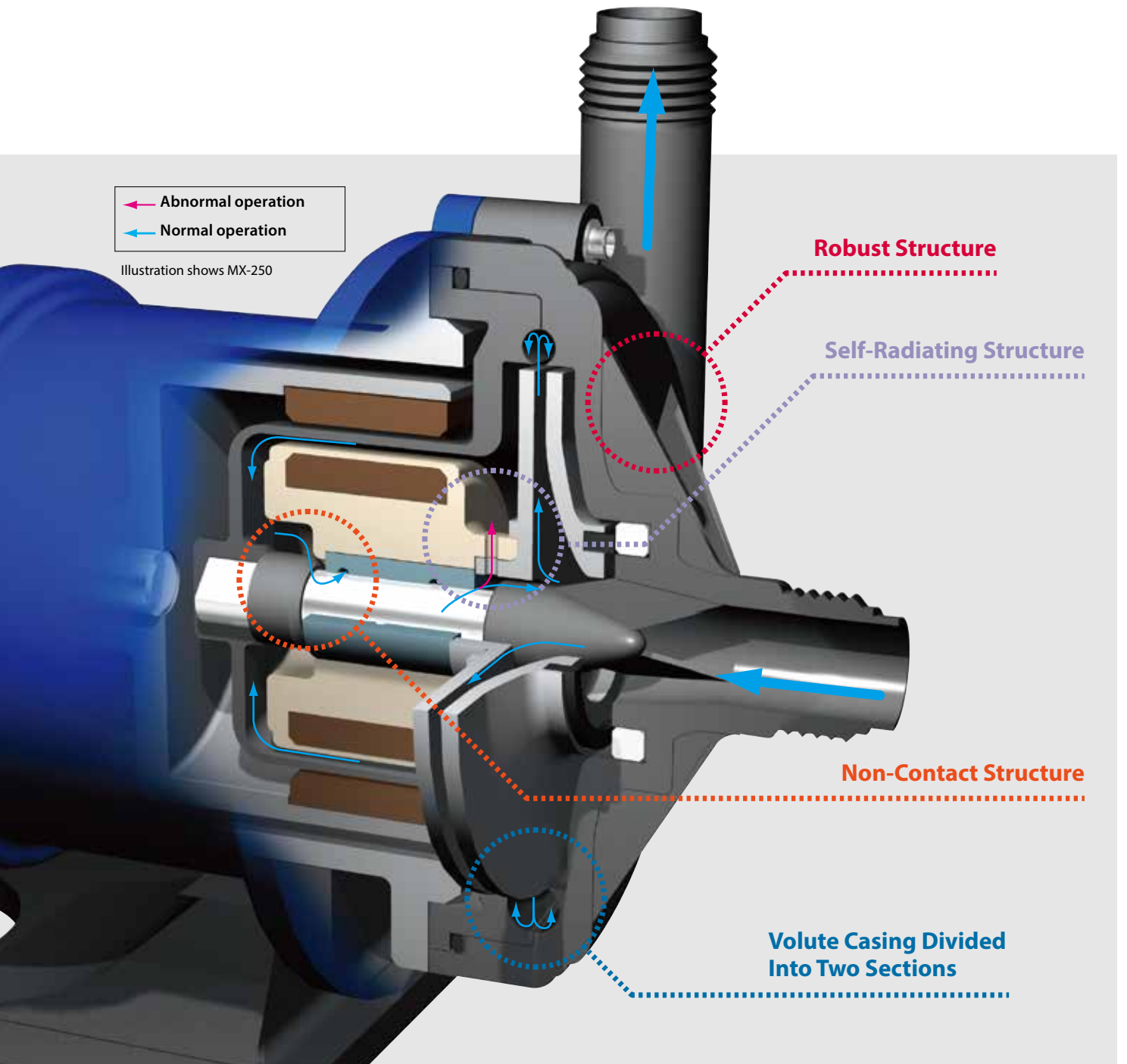

Wet end Materials

■ MX-70,100

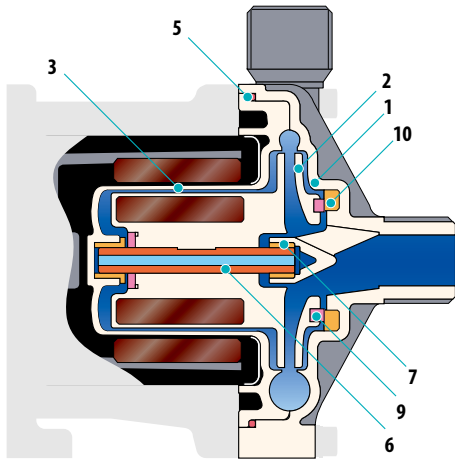

■ MX-250 to 401

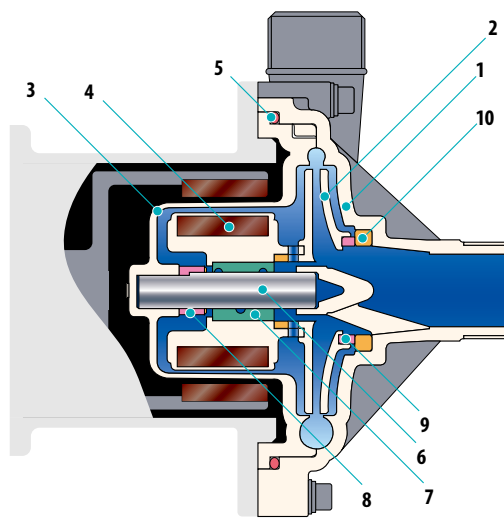

■ MX-402 to 403H

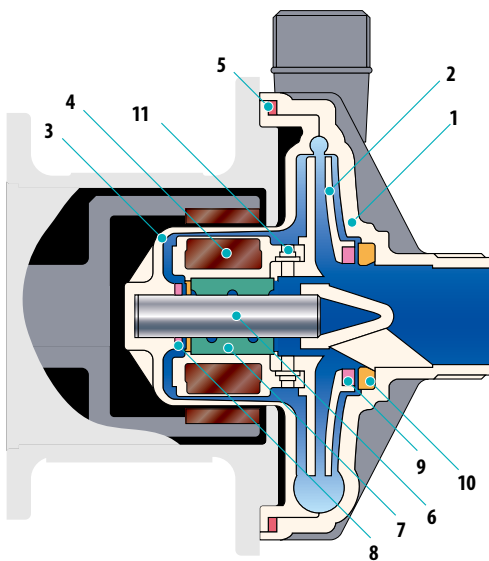

■ MX-505

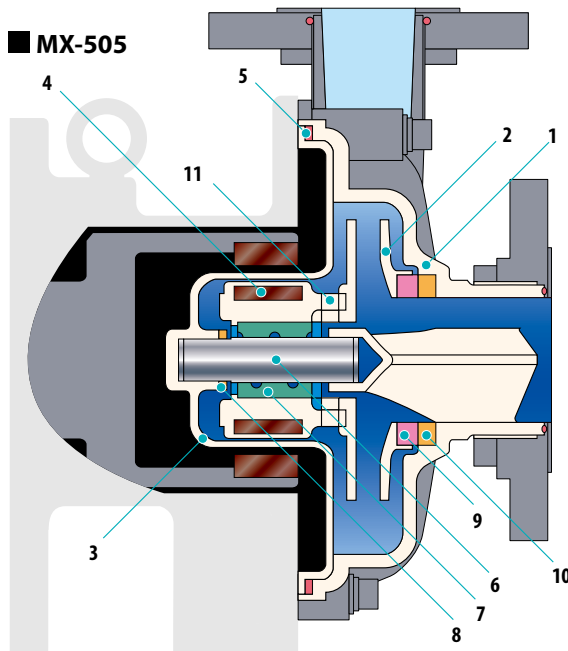

| Model | MX-70 | MX-100 | MX-250 to 505 | | MX-250 to 401 |
|------------------------------|-----------------|-------------------|--|-------------------|-----------------|
| Mark | V/E | | CV/CE | RV/RE | AV/AE |
| 1 Front casing | GFRPP | | GFRPP | | |
| 2 Impeller | CFRPP | | | | |
| 3 Rear casing | GFRPP | | | | |
| 4 Magnet capsule | - | | PP | | |
| 5 O ring <small>Note</small> | FKM(EPDM) | | FKM(EPDM) | | |
| 6 Spindle | Alumina ceramic | | Alumina ceramic | | |
| 7 Bearing | PPS | PTFE(with filler) | Carbon | PTFE(with filler) | Alumina ceramic |
| 8 Rear thrust | - | - | CFRETFE | | |
| 9 Mouth ring | - | PTFE(with filler) | PTFE(with filler) | | |
| 10 Thrust/Liner ring | Alumina ceramic | | Alumina ceramic | | |
| 11 Lock pin | - | | GFRPPS(Only available type 402 to 505) | | - |

Note: An O-ring made of AFLAS* is also available

Pump Identification

| | | |
|--|---|---|
| MX-70 and 100 | | MX - 100 V M |
| | 1 | 2 3 4 |
| 1 Series symbol MX : Material of Casing/GFRPP | 2 Pump size 70 : G1X G1 150W 100 : G1X G1 260W | 3 Materials MX V : FKM (O-ring) E : EPDM (O-ring) |
| | | 4 Connection M : Thread connection |

| | | |
|--|--|--|
| MX-250 to 505 | | MX - 250 CV 5 E - S |
| | 1 | 2 3 4 5 6 |
| 1 Series symbol MX : Material of Casing/GFRPP | 3 Material of Bearing/Spindle/O-ring MX CV,CE : Carbon/Alumina ceramic/FKM(EPDM) RV,RE : PTFE(with filler)/Alumina ceramic/FKM(EPDM) AV,AE : Alumina ceramic/Alumina ceramic/FKM(EPDM) | 5 Motor specification E : IEC motor |
| 2 Pump size 250 : G1 X G1 0.37kW 251 : G1 X G1 0.75kW 400 : G1 1/2 X G1 1/2 0.37kW 401 : G1 1/2 X G1 1/2 0.75kW 402, 402H : G2 X G1 1/2 1.5kW 403, 403H : G2 X G1 1/2 2.2kW 505 : 65A X 50A 4.0kW | 4 Impeller mark MX 5 : 50Hz 7 : 50Hz ^{Note} | 6 Special specification: No mark : Standard S : Order-made specification |

Note: "7" means exclusive IE2 motor. Applicable models are MX-250/251, 400 & 401.

Specifications^(50Hz)

| Model | Connection Suction X Discharge | Limit of S.G. ^{Note 3} | Standard capacity L/min - m | Maximum capacity L/min ^{Note 4} | Motor kW | Mass kg ^{Note 5} |
|---------------------------|-----------------------------------|------------------------------------|--------------------------------|---|-------------|------------------------------|
| MX-70 | G1xG1 ^{Note 2} | 1.2 | 50 - 5.4 | 90 | 0.15 | 6.5 |
| MX-100 ^{Note 1} | G1xG1 ^{Note 2} | 1.2 | 70 - 6 | 110 | 0.26 | 8.2 |
| MX-250 (Impeller mark: 5) | G1xG1 | 1.0 | 50 - 14 | 150 | 0.37 | 7.7 |
| MX-250 (Impeller mark: 7) | | | 50 - 11.7 | | | |
| MX-251 (Impeller mark: 5) | G1xG1 | 1.0 | 80 - 19 | 150 | 0.75 | 10.2 |
| MX-251 (Impeller mark: 7) | | | | | | |
| MX-400 (Impeller mark: 5) | G1 1/2 x G1 1/2 | 1.2 | 100 - 10.5 | 280 | 0.37 | 6.2 |
| MX-400 (Impeller mark: 7) | | | 100 - 9.5 | | | |
| MX-401 (Impeller mark: 5) | G1 1/2 x G1 1/2 | 1.2 | 150 - 14.5 | 320 | 0.75 | 10.2 |
| MX-401 (Impeller mark: 7) | | | | | | |
| MX-402 | G2 x G1 1/2 | 1.2 | 200 - 20 | 450 | 1.5 | 13.5 |
| MX-402H | G2 x G1 1/2 | 1.0 | 100 - 30 | 160 | 1.5 | 13.5 |
| MX-403 | G2 x G1 1/2 | 1.2 | 250 - 23 | 500 | 2.2 | 14.5 |
| MX-403H | G2 x G1 1/2 | 1.0 | 100 - 35 | 300 | 2.2 | 14.5 |
| MX-505 | 65A x 50A | 1.2 | 500 - 24.5 | 800 | 4.0 | 27.0 |

Note 1: MX-F100 performance data and Mass kg are based on using Iwaki standard motor.

The motor to be mounted is an IEC motor.

Note 2: 26mm tube connection option available on the MX-70 and MX-100.

Note 3: The specific gravity limit varies with the discharge. For details, please contact us.

Note 4: AV(AE) type is different in discharge capacity. For details, please contact us.

Note 5: Less motor except MX-70 and 100.

Common specifications

• Range of liquid temperature : 0 to 80°C (10 to 80°C in case AFLAS® O-rings are used.) • Range of ambient temperature : 0 to 40°C.

Performance Curves

50Hz

MX-70/100

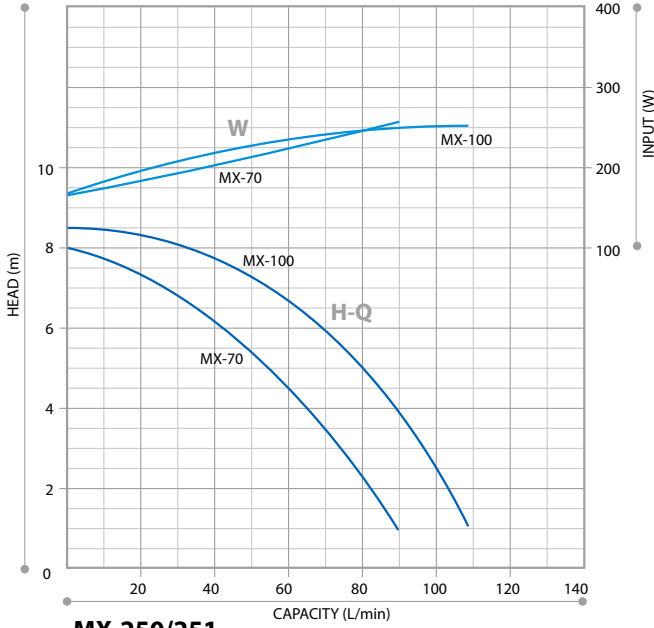

MX-402/402H

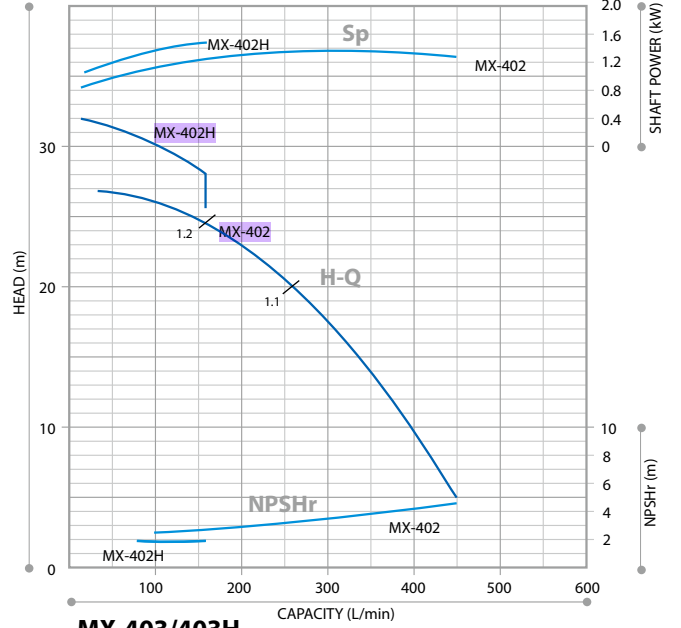

MX-250/251

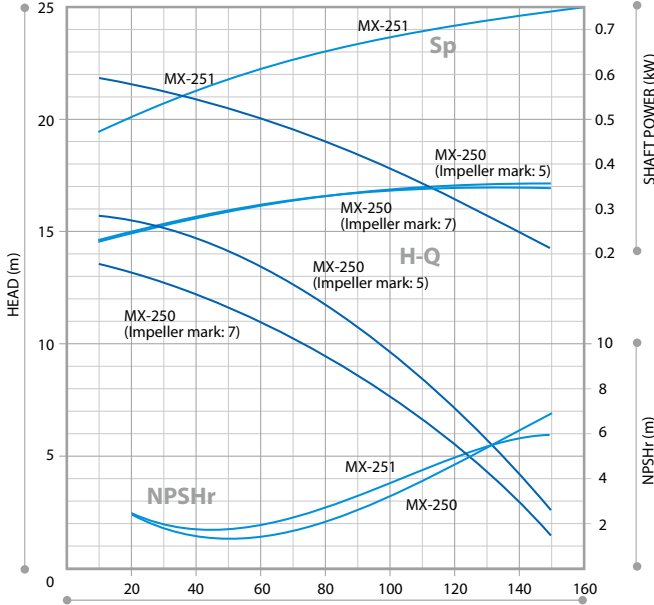

MX-403/403H

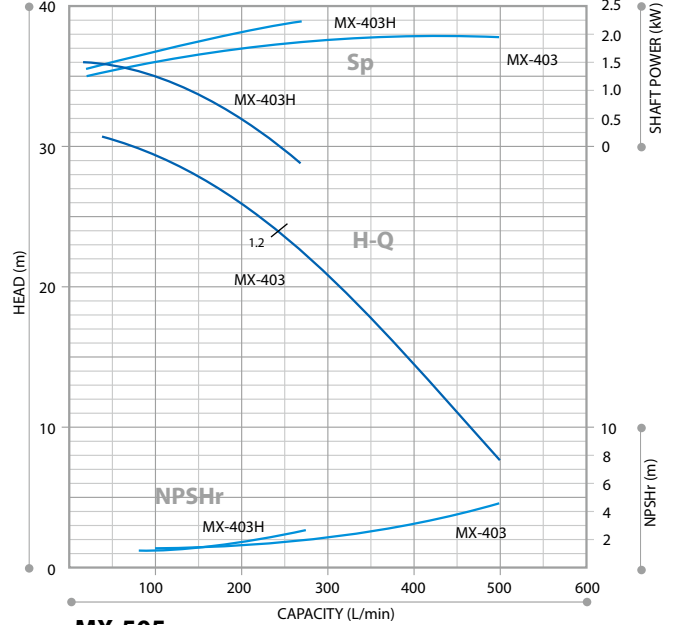

MX-400/401

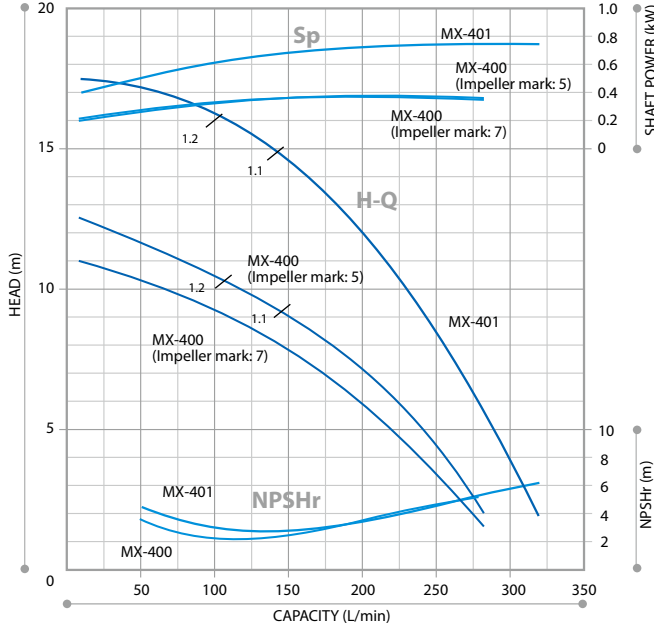

MX-505

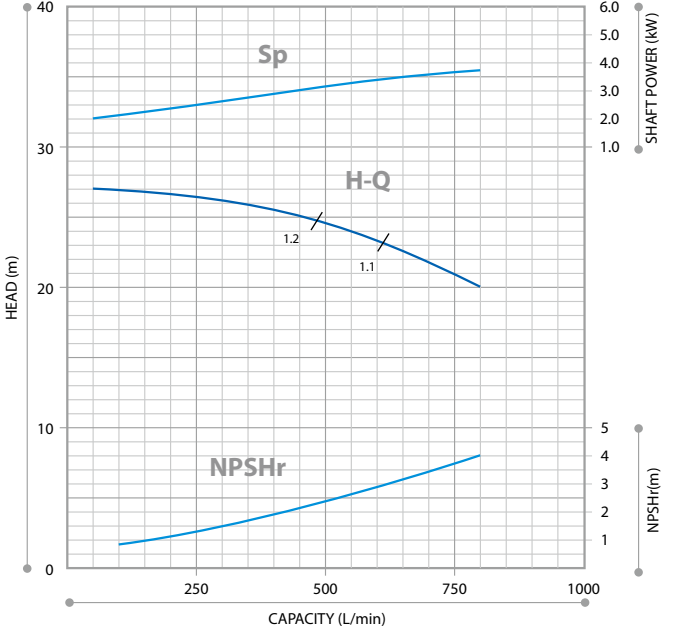

Dimensions (mm)

■ MX-70, 100 Note 1, 2

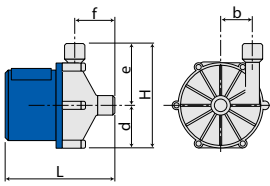

■ MX-250 to 401

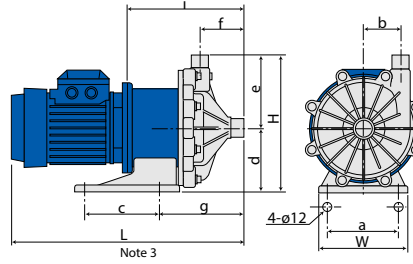

■ MX-402, 402H, 403, 403H

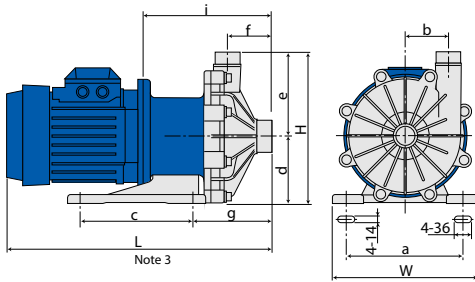

■ MX-505

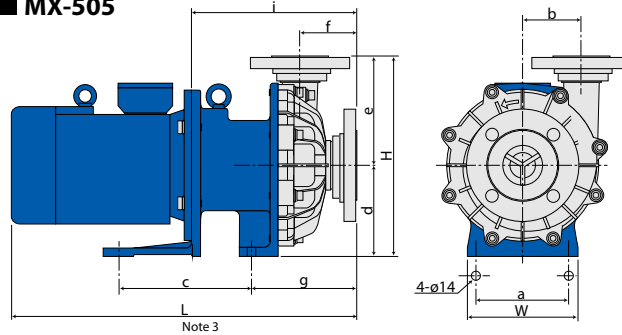

| Models | W | H | L | a | b | c | d | e | f | g | i |
|-------------|-----|-------|-------|-----|----|-----|-----|-------|------|-------|-------|
| MX-70 | – | 154 | 142.5 | – | 48 | – | 64 | 90 | 53 | – | – |
| MX-100 | – | 169 | 177 | – | 51 | – | 69 | 100 | 65 | – | – |
| MX-250 | 160 | 247.5 | – | 130 | 65 | 130 | 115 | 132.5 | 82.5 | 155.5 | 213.5 |
| MX-251 | 160 | 247.5 | – | 130 | 65 | 130 | 115 | 132.5 | 82.5 | 163.5 | 225.5 |
| MX-400 | 140 | 219 | – | 110 | 54 | 98 | 95 | 124 | 81 | 144 | 215 |
| MX-401 | 160 | 249 | – | 130 | 72 | 130 | 115 | 134 | 97 | 178 | 240 |
| MX402, 402H | 260 | 274 | – | 208 | 80 | 200 | 120 | 154 | 83 | 151 | 235 |
| MX403, 403H | 260 | 274 | – | 208 | 80 | 200 | 120 | 154 | 83 | 151 | 235 |
| MX-505 | 180 | 330 | – | 140 | 96 | 220 | 150 | 180 | 95 | 175 | 275 |

Note 1: MX-70 and MX-100 show thread type in the above dimensions, Please contact us for tube connection type.

Note 2: MX-70 and MX-100 outer dimensions are without a motor. For the motor mounting dimensions, please contact us.

Note 3: The dimensions L may differ with the type of motor installed.

Optional Accessories

IWAKI Pump Protector DRN Series

Detects Unusual Pump Operating Conditions Including Dry-Running and Overload

The DRN model protects equipment (including pumps) from damage!

Minimizes production downtime.

Identifies possible causes of alarms so they can be investigated and addressed.

| | |
|--------------------|---|
| Multiple Input | Two analog, one digital, one temperature input and one current input |
| Easy operation | Equipped with EASY setup mode to remember the operation status and set the lower/upper limit values, as well as AUTO setup mode |
| Bar graph | Visible indication of current operating status |
| Logging capability | Data log feature for preventative maintenance scheduling |
| Communication | RS485 external communication capability |



Specifications

| Model | DRN-01 | DRN-02 |
|-----------------------|-------------------------|------------|
| Amperometric range | 0.5-30.00A | 5.0-200.0A |
| Unit's source voltage | AC100-240V 50/60Hz 10VA | |
| Operating temperature | 0-40°C | |
| Operating humidity | 35-85%RH | |

IWAKI Process Magnetic Drive Pump Series

MX-F Series

Withstands Difficult Operating Conditions and Offers High Efficiency

Max. discharge capacity: 510 L/min
Max. discharge head: 30 m
Main materials: CFRETFE



SMX Series

Versatile Self-Priming Magnetic Drive Pump with Enhanced Durability Under Abnormal Operation

Max. discharge capacity: 440 L/min
Max. head: 25.5 m
Main materials: GFRPP, CFRETFE



MXM Series

Magnetic Drive Pumps with an Excellent Balance of Features and Performance

Max. discharge capacity: 600 L/min
Max. head: 29 m
Main materials: CFRETFE



MDM Series

Magnetic Drive Processing Pump with Dry Running Capability

Max. discharge capacity: 1800L/min
Max. head: 74 m
Main materials: CFRETFE, PFA



IWAKI CO., LTD. 6-6 Kanda-Sudacho 2-chome Chiyoda-ku Tokyo 101-8558 Japan TEL : (81)3 3254 2935 FAX : 3 3252 8892

IWAKI has global net work. Please find your distributor location at

www.iwakipumps.jp

| | | | | | |
|--------------------------------------|--|------------------------|------------------------------|--|-----------------------|
| European Headquarter Germany | IWAKI Europe GmbH TEL: (49)2154 9254 0 | FAX: (49)2154 9254 48 | U.S.A. | IWAKI America Inc. TEL: (1)508 429 1440 | FAX: (1)508 429 1386 |
| The Netherlands (Netherlands Branch) | IWAKI Europe GmbH TEL: (31)74 2420011 | FAX: (49)2154 9254 55 | Brazil | IWAKI Do Brasil Comercio De Bombas Hidraulicas LTDA. TEL: (55)19 3244 5900 | FAX: (55)19 3244 5900 |
| Italy (Italy Branch) | IWAKI Europe GmbH TEL: (39)0445 561219 | FAX: (49)2154 9254 48 | China (Shanghai) | IWAKI Pumps (Shanghai) Co., Ltd. TEL: (86)21 6272 7502 | FAX: (86)21 6272 6929 |
| Spain (Spain Branch) | IWAKI Europe GmbH TEL: (34)934 741 638 | FAX: (39)0445 569088 | China (Hong Kong) | IWAKI Pumps Co., Ltd. TEL: (852)2607 1168 | FAX: (852)2607 1000 |
| Poland (East Europe Branch) | IWAKI Europe GmbH TEL: (48)12 347 0755 | FAX: (34)934 741 638 | China (Guangzhou) | GFTZ IWAKI Engineering & Trading Co., Ltd. TEL: (86)20 84350603 | FAX: (86)20 84359181 |
| Denmark | IWAKI Nordic A/S TEL: (45)48 242345 | FAX: (48)12 347 0900 | Singapore | IWAKI Singapore Pte Ltd. TEL: (65)6316 2028 | FAX: (65)6316 3221 |
| Finland | IWAKI Suomi Oy TEL: (358)10 201 0490 | | Indonesia (Indonesia Office) | IWAKI Singapore Pte Ltd. TEL: (62)21 6906606 | FAX: (62) 21 6906612 |
| Norway | IWAKI Norge AS TEL: (47)23 38 49 00 | | Malaysia | IWAKim SDN. BHD. TEL: (60)3 7803 8807 | FAX: (60)3 7803 4800 |
| Sweden | IWAKI Sverige AB TEL: (46)8 511 72900 | | Korea | IWAKI Korea Co.,Ltd. TEL: (82)2 6238 4800 | FAX: (82)2 6238 4801 |
| Belgium | IWAKI Belgium N.V. TEL: (32)13 670200 | FAX: (32)13 672030 | Taiwan | IWAKI Pumps Taiwan Co., Ltd. TEL: (886)2 8227 6900 | FAX: (886)2 8227 6818 |
| France | IWAKI France S.A. TEL: (33)1 69 63 33 70 | FAX: (33)1 64 49 92 73 | Thailand | IWAKI (Thailand) Co.,Ltd. TEL: (66)2 322 2471 | FAX: (66)2 322 2477 |
| | | | Australia | IWAKI Pumps Australia Pty Ltd. TEL: (61)2 9899 2411 | FAX: (61)2 9899 2421 |

() Country codes

Caution for safety use: Before use of pump, read instruction manual carefully to use the product correctly. Actual pumps may differ from the photos. Specifications and dimensions are subject to change without prior notice. For further details please contact us.

Legal attention related to export. Our products and/or parts of products fall in the category of goods contained in control list of international regime for export control. Please be reminded that export license could be required when products are exported due to export control regulations of countries. The posting and copying from this catalogue without permission is not accepted firmly.